



DATA SHEET

SNAP Engine 300 Series

Model Number: RF300

Part Number: RF300PD1

©2008-2014 Synapse, All Rights Reserved. All Synapse products are patent pending. Synapse, the Synapse logo, SNAP, and Portal are all registered trademarks of Synapse Wireless, Inc.

Doc# 430135-01B

6723 Odyssey Drive // Huntsville, AL 35806 // (877) 982-7888 // Synapse-Wireless.com

SNAP Engine 300 Series Modules Overview

The SNAP Engine 300 Series (Model Number RF300) is a low power, highly-reliable solution to embedded wireless control and monitoring network needs that require high data rates. The RF300 embeds Synapse's SNAP OS, the industry's first Internet enabled, wireless, mesh network operating system into the Silicon Laboratories Si1000 single-chip microcontroller with an integrated transceiver that delivers up to 150kbps. These low-cost modules can have a range of up to 3 miles and current consumption less than 16 μ A to enable a new generation of battery-driven systems.

SNAP's on-board Python interpreter provides for rapid application development and over-the-air programming, while Silicon Laboratories' low-power RF single-chip design saves board space and lowers the overall Bill of Materials and power consumption. The RF300 is approved as an FCC Part 15 unlicensed modular transmitter. The modules provide up to 16 channels of operation in the ISM 915MHz frequency band. The on-board Si1000 transceiver contains both a power amplifier for transmission and a low noise amplifier in the receive path for extended range.

This Data Sheet details Part Number RF300PD1, which includes:

- 15 GPIO and up to 12 A/D inputs
- 192K total FLASH with 64K used by SNAP core, 64K free for uploadable SNAPpy scripts, and 64K reserved
- UART port for control or transparent data
- Low power modes: <16 μ A with internal timer running
- Frequency Hopping (FHSS) technology
- Socket-able or solder-able
- 150Kbps RF Data Rate
- 915 MHz RF Frequency
- SMA antenna (up to 3 miles LoS)
- AES 128-bit encryption

The RF300 is also available with a U.FL connector.
Contact Synapse for details.

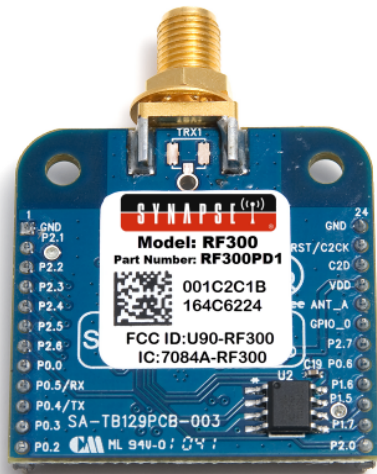

Specifications

Table 1.1: RF300PD1 Specifications at 25° C

Performance	Outdoor LOS Range	Up to 3 miles at 150Kbps
	Transmit Power Output	20 dBm
	RF Data Rate	150Kbps
	Receiver Sensitivity	-99 dBm (1% PER)
Power Requirements	Supply Voltage	2.7 - 3.6 V
	Transmit Current (Typ@3.3V)	85mA
	Idle/Receive Current (Typ@3.3V)	24.2mA
	Power-down Current (Typ@3.3V)	Timed: .9μA Untimed: .2μA
General	Frequency	ISM 915 MHz
	Spreading Method	FHSS
	Modulation	GFSK
	Dimensions	1.333" x 1.333"
	Operating Temperature	- 40 to 85 deg C.
	Antenna Options	External RPSMA
Networking	Topology	SNAP
	Error Handling	Retries and acknowledgement
	Number of Channels	16
Available I/O	UARTS with HW Flow Control	1 Port
	GPIO	15 total; 12 can be analog-in with 10bit ADC
Agency Approvals	FCC Part 15.247	FCC ID: U90-RF300
	Industry Canada (IC)	IC: 7084A-RF300

Module Pin Definitions

Table 1.2: RF300PD1 Module Pin Assignments

Pin	SNAPpy IO	Name	Description
1		GND	Power Supply
2	10	GPIO0/ADC17/P2.1	GPIO_0, ADC17, I ² C SDA
3	11	GPIO1/ADC18/P2.2	GPIO_1, ADC18, I ² C SCL

Pin	SNAPpy IO	Name	Description
4	12	GPIO2/ADC19/P2.3	GPIO_2, ADC19
5	13	GPIO3/ADC20/P2.4	GPIO_3, ADC20
6	14	GPIO4/ADC21/P2.5	GPIO_4, ADC21, SPI MOSI
7	15	GPIO5/ADC22/P2.6	GPIO_5, ADC22, SPI SCLK
8	0	GPIO6/ADC0/P0.0/V _{REF}	GPIO_6, ADC0, Interrupt, External Voltage Reference, SPI MISO
9	4	GPIO7/ADC5/P0.5/UART_RX	GPIO_7, ADC5, Interrupt, UART0 Rx Data Input
10	3	GPIO8/ADC4/P0.4/UART_TX	GPIO_8, ADC4, Interrupt, UART0 Tx Data Output
11	2	GPIO9/ADC3/P0.3/CTS	GPIO_9, ADC3, UART0 CTS Output
12	1	GPIO10/ADC2/P0.2/RTS	GPIO_10, ADC2, Interrupt, UART0 RTS Input
13	(9)	[GPIO11/ADC16/P2.0]	Not Available, Do Not Connect ¹
14	(8)	[GPIO12/ADC15/P1.7]	Not Available, Do Not Connect ¹
15	(6)	[GPIO13/ADC13/P1.5]	Not Available, Do Not Connect ¹
16	(7)	[GPIO14/ADC14/P1.6]	Not Available, Do Not Connect ¹
17	5	GPIO15/ADC6/P0.6/CNVSTR	GPIO_15, ADC6, External "Start Conversion" for ADC0
18	16	GPIO16/P2.7	GPIO_16 ²
19	17	GPIO17	GPIO_17
20	18	ANT_A	GPIO_18 (Output Only)
21		V _{CC}	Power Supply
22		C2D	Background Debug Communications
23		RESET	Module Reset, Active Low
24		GND	Power Supply

¹ Pins 13 – 16 are not available for use on the RF300 and should not be tied to any signals. These pins are used for access to the onboard external memory.

² GPIO16 has limited drive strength as it is routed through a 1Kohm resistor. The signal driven from (or to) GPIO16 can also be read, or driven, on pin 22 (CD2), the debug pin.

Electrical Characteristics

Table 1.3: RF300 Series DC Characteristics at 25° C

Symbol	Parameter	Condition	Min	Typ	Max	Units	
V_{CC}^3	Supply Voltage		2.7	3.3	3.6	V	
T_{OP}	Operating Temp		-40		85	°C	
T_{STOR}	Storage Temp		-40		125	°C	
V_{IH}	Input Hi Voltage	All Digital Inputs	$V_{CC} - 0.6$			V	
V_{IL}	Input Low Voltage	All Digital Inputs			0.6	V	
V_{OL}	Output Low Voltage	High Drive Strength	$I_{OL} = 8.5\text{ma}$			0.6	V
			$I_{OL} = 10\mu\text{A}$			0.1	
			$I_{OL} = 25\text{mA}$		Note ⁴		
		Low Drive Strength	$I_{OL} = 1.4\text{ma}$			0.6	
			$I_{OL} = 10\mu\text{A}$			0.1	
			$I_{OL} = 4\text{mA}$		Note ³		
V_{OH}	Output High Voltage	High Drive Strength	$I_{OH} = -3\text{ma}$	$V_{CC} - 0.7$			V
			$I_{OH} = -10\mu\text{A}$	$V_{CC} - 0.1$			
			$I_{OH} = -10\text{mA}$		Note ³		
		Low Drive Strength	$I_{OL} = 1.4\text{ma}$	$V_{CC} - 0.7$			
			$I_{OL} = 10\mu\text{A}$	$V_{CC} - 0.1$			
			$I_{OL} = 4\text{mA}$		Note ³		
$I_{L_{IN}}$	In Leakage Current	Weak PU On, $V_{IN} = 0\text{V}$, $V_{CC} = 3.6\text{V}$		20	30	μA	
$\text{TX-}I_{CC}$	Transmit Current	$V_{CC} = 3.3\text{V}$		85		mA	
$\text{RX-}I_{CC}$	Receive Current	$V_{CC} = 3.3\text{V}$		18.5		mA	
$\text{SHDN-}I_{CC}$	Sleep Current			8	16	μA	

3 Absolute maximum stress rated voltage for VCC is -0.3 to 3.6. It is recommended that bulk capacitance be located as close as possible to the VCC pin on the host board. Ideally, use a single 47 μF capacitor at 10V directly at the VCC pin.

4 See Si100X datasheet for output current curves.

Table 1.4: ADC Electrical Characteristics (Operating)

Symbol	Parameter	Condition	Min	Typical	Max	Unit
V_{REF}	Voltage Reference	Internal-Fast		1.65		V
		Internal-Precision		1.68		
		External	0		V_{CC}	
V_{INDC}	Analog input voltage	Absolute Voltage	0		V_{CC}	V
		ADC Input Range	0		V_{REF}	

Table 1.5: ADC Timing/Performance Characteristics

Symbol	Parameter	Condition	Min	Typical	Max	Unit
R_{AS}	Source impedance at input			5		k Ω
RES	Conversion Resolution			10		Bits
INL	Integral non-linearity			0.5	1	LSB
E_{OFF}	Offset Error			<1	2	LSB
E_{FS}	Full Scale Error			1	2.5	LSB

Mechanical Drawings

These drawings in **Figure 1.1** show the module with the RPSMA connector for use with an external antenna.

NOTE: The area under the module's antenna (marked NO COPPER or KEEP OUT AREA) should have no components, no traces, and no copper on any layer of the printed circuit board.

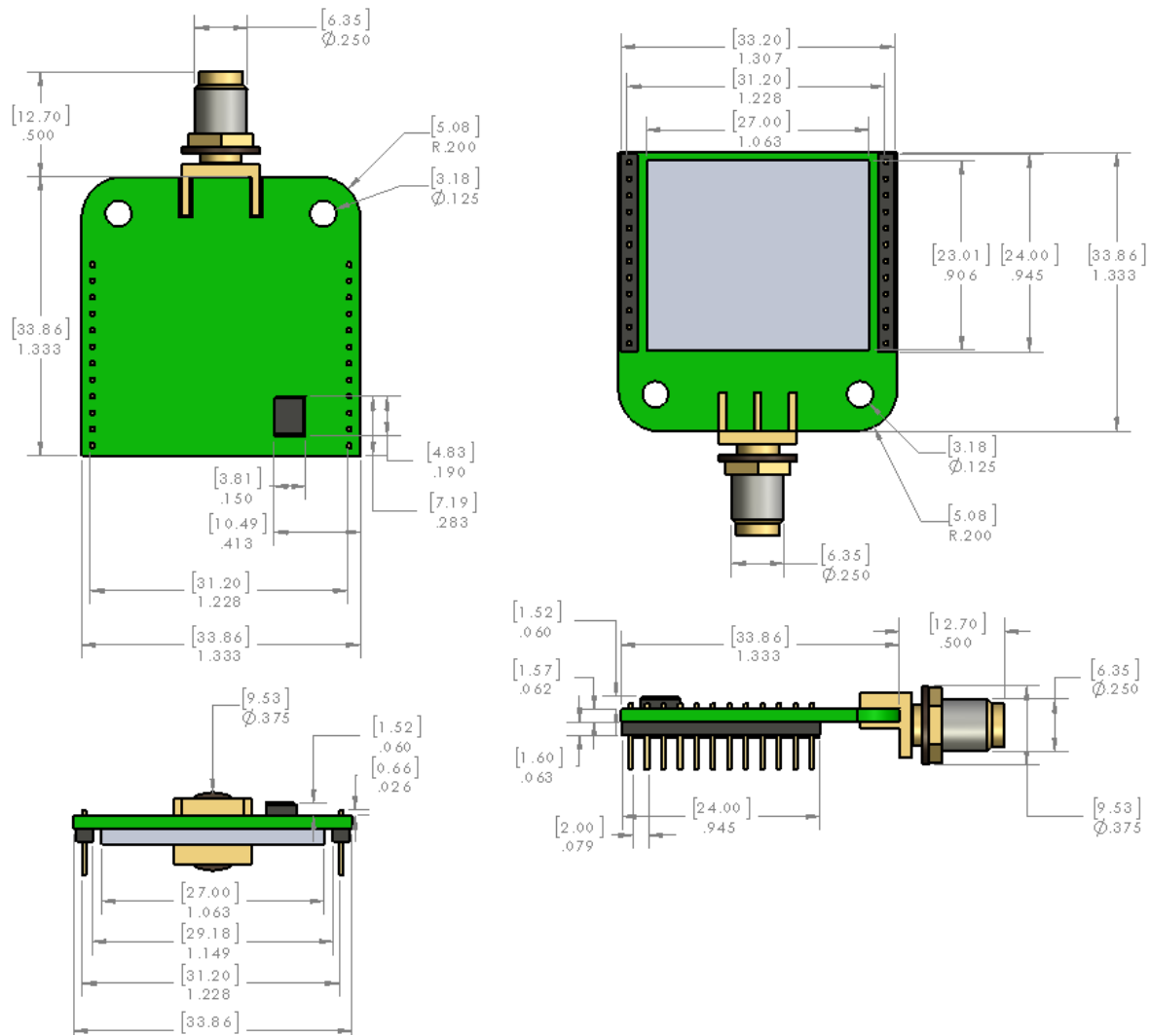

NOTE: Metric measurements are between brackets, with standard measurements below.

Figure 1.1: Mechanical drawings of the RF300PD1 Module

Board Mounting Considerations

The RF300PD1 module is designed to mount into a receptacle (socket) on the host board. **Figure 1.2** shows an RF300PD1 module plugged into a host board. The receptacle sockets are on standard 2mm centers. Suggested receptacles to be used on the host are:

Thru-hole receptacle	Samtec	MMS-112-01-L-SV
Surface mount receptacle	Samtec	MMS-112-02-L-SV

It is recommended that the mounting holes provided in the module on either side of the SMA connector be used with supporting mounting hardware to hard mount the module to either the host board or to the

enclosure to handle the mechanical stresses that can occur when an external antenna is screwed into the SMA. **Figure 1.2** shows the RF300PD1 with SMA connector mounted to the host board.

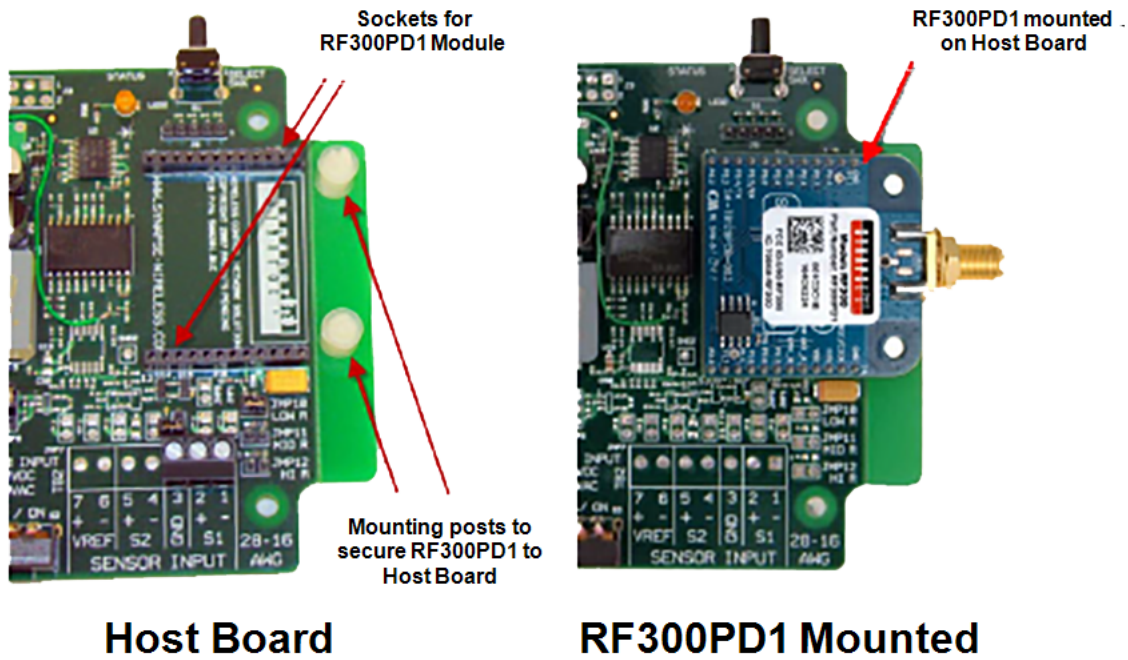

Figure 1.2: RF300PD1 Mounted To Host Board

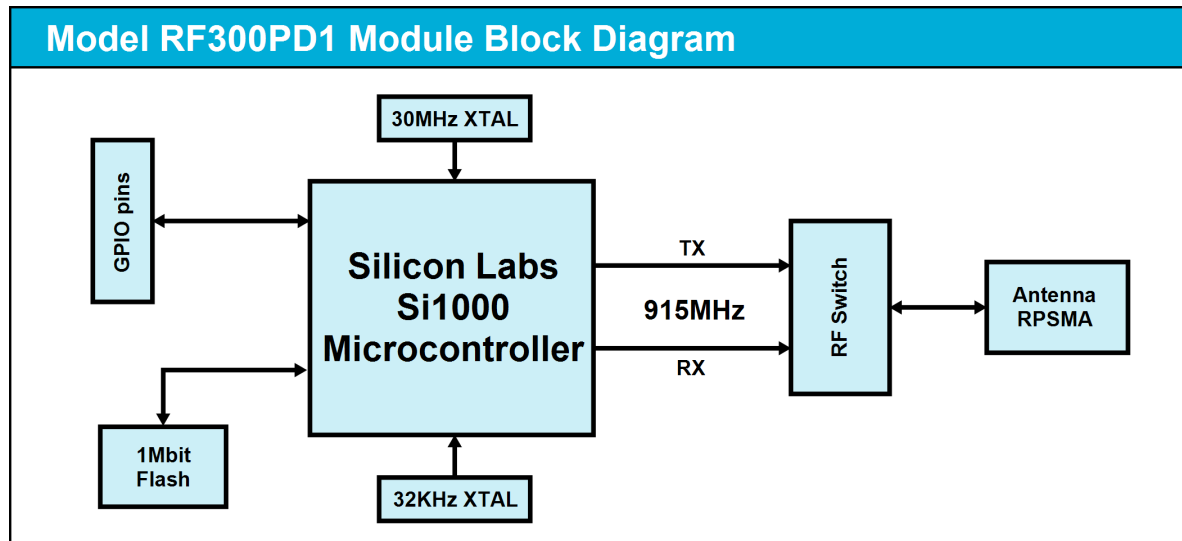

Figure 1.3: Block diagram showing the major subsystems comprising the RF300PD1

Agency Certifications

United States (FCC)

The Model RF300 modules comply with Part 15 of the FCC rules and regulations. Compliance with the labeling requirements, FCC notices, and antenna usage guidelines is required. In order to comply with FCC Certification requirements, the Original Equipment Manufacturer (OEM) must fulfill the following requirements.

1. The system integrator must place an exterior label on the outside of the final product housing the RF300 Modules. **Figure 2.1** below shows the contents that must be included on this label.
2. RF300 Modules may only be used with the antenna that has been tested and approved for use with the module. Please refer to the antenna table provided in this section.

OEM Labeling Requirements

NOTICE: The OEM must make sure that FCC labeling requirements are met. This includes a clearly visible exterior label on the outside of the final product housing that displays the contents shown in **Figure 2.1** below.

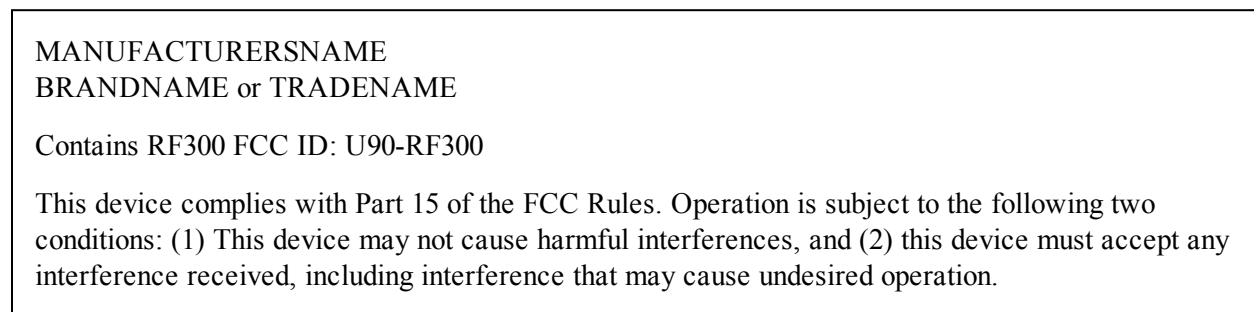

Figure 2.1: FCC Label

FCC Notices

WARNING! The RF300 modules have been tested by the FCC for use with other products without further certification (as per FCC Section 2.1091). Changes or modifications to this device not expressly approved by Synapse Wireless Inc. could void the user's authority to operate the equipment.

NOTICE: OEM's must certify final end product to comply with unintentional radiators (FCC Sections 15.107 and 15.109) before declaring compliance of their final product to Part 15 of the FCC Rules.

NOTICE: The RF300 modules have been certified for remote and base radio applications. If the module will be used for portable applications as defined by the FCC, the device must undergo SAR testing.

This equipment has been tested and found to comply with the limits for a Class B digital device, pursuant to Part 15 of the FCC Rules. These limits are designed to provide reasonable protection against harmful

interference in a residential installation. This equipment generates, uses, and can radiate radio frequency energy, and if not installed and used in accordance with the instructions, may cause harmful interference to radio communications. However, there is no guarantee that interference will not occur in a particular installation.

If this equipment does cause harmful interference to radio or television reception, which can be determined by turning the equipment off and on, the user is encouraged to try to correct the interference by one or more of the following measures:

- Reorient or relocate the receiving antenna.
- Increase the separation between the equipment and receiver.
- Connect the equipment into an outlet on a circuit different from that to which the receiver is connected.
- Consult the dealer or an experienced radio/TV technician for help.

FCC Approved Antennas

The RF300 modules are FCC-approved for fixed base station and mobile applications.

Notice: To reduce potential radio interference to other users, the antenna type and its gain should be chosen so that the equivalent isotropically radiated power (EIRP) is not more than that permitted for successful communication. This module has been designed to operate with the antennas listed below in **Table 2.1**. The required antenna impedance is 50 ohms.

Table 2.1: Approved Antennas

Part Number	Type	Gain	Application	Min. Separation
Linx ANT-916-CW-RCL	Dipole (quarter-wave RPSMA)	0.47 dBi	Fixed/Mobile	20 cm.

For more information on approved antennas, please consult the manufacturer's website.

WARNING! RF Exposure: This equipment complies with FCC radiation exposure limits set forth for an uncontrolled environment. This equipment should be installed and operated with minimum distance 20cm between the radiator and your body. This transmitter must not be co-located or operating in conjunction with any other antenna or transmitter.

NOTICE: The preceding statement must be included as a CAUTION statement in OEM product manuals in order to alert users of FCC RF exposure compliance.

NOTE: Antenna and transmitters may be co-located or operated in conjunction with this device only if the transmitters do not simultaneously transmit. Otherwise, additional regulatory requirements will apply.

Canada (IC)

This device complies with Industry Canada license-exempt RSS standard(s). Operation is subject to the following two conditions: (1) this device may not cause interference, and (2) this device must accept any

interference, including interference that may cause undesired operation of the device.

Le présent appareil est conforme aux CNR d'Industrie Canada applicables aux appareils radio exempts de licence. L'exploitation est autorisée aux deux conditions suivantes : (1) l'appareil ne doit pas produire de brouillage, et (2) l'utilisateur de l'appareil doit accepter tout brouillage radioélectrique subi, même si le brouillage est susceptible d'en compromettre le fonctionnement.

Under Industry Canada regulations, this radio transmitter may only operate using an antenna of a type and maximum (or lesser) gain approved for the transmitter by Industry Canada. To reduce potential radio interference to other users, the antenna type and its gain should be so chosen that the equivalent isotropically radiated power (EIRP) is not more than that necessary for successful communication.

Conformément à la réglementation d'Industrie Canada, le présent émetteur radio peut fonctionner avec une antenne d'un type et d'un gain maximal (ou inférieur) approuvé pour l'émetteur par Industrie Canada. Dans le but de réduire les risques de brouillage radioélectrique à l'intention des autres utilisateurs, il faut choisir le type d'antenne et son gain de sorte que la puissance isotrope rayonnée équivalente (p.i.r.e.) ne dépasse pas l'intensité nécessaire à l'établissement d'une communication satisfaisante.

This radio transmitter Model: RF300 FCC ID: U90-RF300 has been approved by Industry Canada to operate with the antenna types listed below with the maximum permissible gain and required antenna impedance for each antenna type indicated. Antenna types not included in this list, having a gain greater than the maximum gain indicated for that type, are strictly prohibited for use with this device.

Le présent émetteur radio Model: RF300, IC: 7084A-RF300 a été approuvé par Industrie Canada pour fonctionner avec les types d'antenne énumérés ci-dessous et ayant un gain admissible maximal et l'impédance requise pour chaque type d'antenne. Les types d'antenne non inclus dans cette liste, ou dont le gain est supérieur au gain maximal indiqué, sont strictement interdits pour l'exploitation de l'émetteur.

Table 2.2: Approved Antennas

Part Number	Type	Gain	Application	Min. Separation
Linx ANT-916-CW-RCL	Dipole (quarter-wave RPSMA)	-	Fixed/Mobile	20 cm.

OEM Labeling Requirements

Labeling requirements for Industry Canada are similar to those of the FCC. A clearly visible label on the outside of the final product housing must display the contents shown in **Figure 2.2** below.

<p>MANUFACTURERSNAME BRANDNAME or TRADENAME MODEL: Contains RF300 IC: 7084A-RF300</p>
--

Figure 2.2: IC Label

NOTE: The OEM can choose to implement a single label combined for both FCC and IC labeling requirements. If a combined single label is chosen, there must be a clearly visible label on the outside of the final product housing displaying the contents shown in **Figure 2.3** below.

MANUFACTURERSNAME
BRANDNAME or TRADENAME

Contains RF300 FCC ID: U90-RF300

Contains RF300 IC: 7084A-RF300

This device complies with Part 15 of the FCC Rules. Operation is subject to the following two conditions: (1) This device may not cause harmful interferences, and (2) this device must accept any interference received, including interference that may cause undesired operation.

Figure 2.3: Combined FCC and IC Label